



up grade

Journal (KS) for customers, partners and employees – 17th year, issue no. 17, Dec 2017

News

Investment in the building trade

Cautious optimism in the building sector also in Eastern Europe and Central Asia keeps going the tendency to invest shown by producers of building materials. This became obvious at the trade fairs in Kiev (Ukraine), Tashkent (Uzbekistan) and Almaty (Kazakhstan) attended by LASCO in 2017.

Know-how

Retrofitting with hydraulic servo direct drive

The hydraulic servo direct drive for LASCO sand-lime block presses launched only a few years ago fully comes up to the expectations placed in it wherever it is used. Now LASCO offers this drive technology also for the retrofitting of existing lines.

In practice

Production rejigged completely

LASCO developed a special press for the production of salt blocks at the "European salt company (esco)", which are used in animal rearing and livestock breeding. The mineral nutrient salt and the high hygienic standards in the feed industry turned the project into an extraordinary challenge.

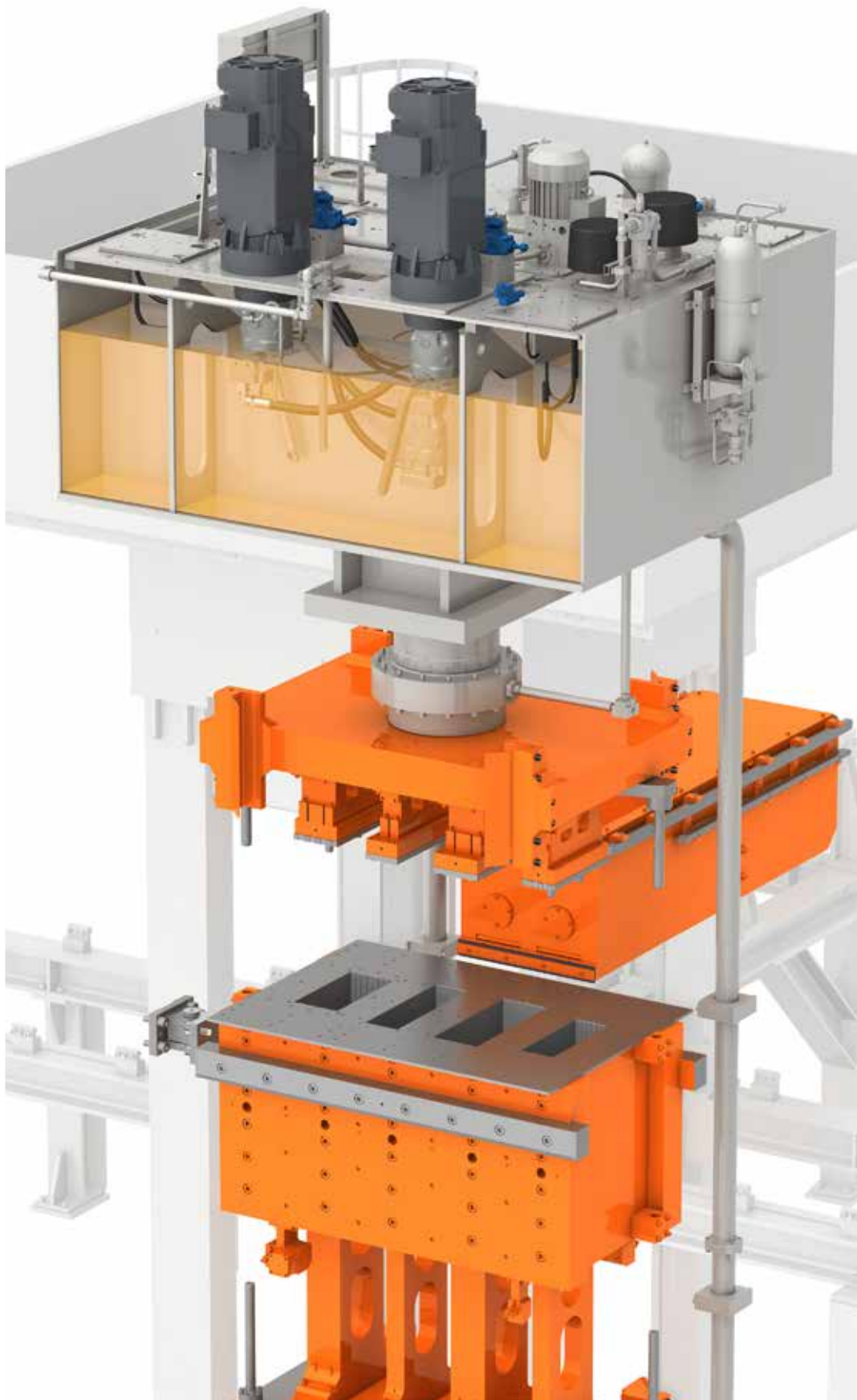



Lothar Bauersachs
CEO
LASCO Umformtechnik GmbH

Renaissance of protectionism?

Globalization deeply changed our economic system, boosted growth and wealth in many places of the world, but also increased competition considerably. This put entrepreneurs, employees and economic areas that were not sufficiently competitive under pressure, and provided the breeding ground for the strengthening of populism and nationalism.

Statements like „Imports lose us our jobs“ manifest this view.

We as enterprises are therefore well-advised not to let it get to ourselves, but to rely on what evidently generated our previous success. Open markets and free trade are necessary preconditions for jobs and prosperity. This is true for today and the future none the less than it was over decades in the past, in which this was general economic knowledge, though.

The rather quiet time of contemplation around the turn of the year gives us the chance of pausing a little and summon up strength for the challenges lying ahead of us. I wish you and our employees a lot of success in doing so, and look forward to meeting you again in 2018.

Yours

Lothar Bauersachs

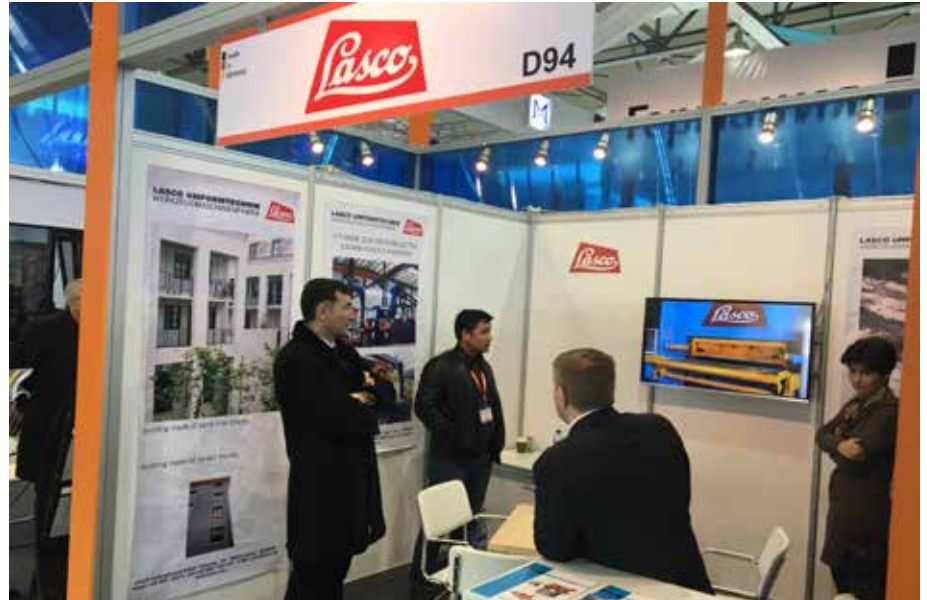

LASCO informed business partners and prospective buyers about new technologies for building material production and exchanged experiences with them. The picture shows the LASCO stand at the KievBuild.

Trade fairs in Kiev, Kazakhstan and Uzbekistan
Cautious optimism in Eastern Europe and Central Asia

The building sector in Eastern Europe and Central Asia has to cope with an inconsistent economic situation at present as well as in the foreseeable future. Nevertheless, optimism prevails.

This became obvious in a lot of interesting discussions with LASCO's established business partners as well as prospective buyers held at the international trade fairs KievBuild in Kiev/Ukraine, UzBuild in Tashkent/Uzbekistan (both in March 2017) and KazBuild in Almaty/Kazakhstan (September 2017). In the Ukraine, the industry concentrates its hopes on an end of the unrest and a rapprochement with Russia. As former Soviet Republics, Uzbekistan and Kazakhstan are directly affected by the conflict due to their traditional links with Russia and the Ukraine.

LASCO has had excellent business relations to all three countries for many decades, and the same applies to those with Russian

partners. The difficult situation was special motivation to participate in the trade fairs in order to cultivate and strengthen contacts.

The KievBuild has been the leading international trade fair for construction and interior finishing in the Ukraine for 20 years. This year participants from 15 different countries were present. The UzBuild has become the leading trade fair of the Uzbek construction and interior finishing industry and attracts the attention of specialists from all over the world. For the 7th time already, the German Federal Ministry for Economic Affairs and Energy participated in it with a joint German pavilion, where 13 German companies presented their exhibits.



The KazBuild is an international construction trade fair and major meeting point of property developers in Kazakhstan.





The participants of the 3rd International trade conference "White Stone" in Jaroslavl, Russia.

Dreher group orders retrofitting of machines

Technology push in Hesse (Germany)

The Dreher group relies on LASCO as technology leader and brings the production site Mörfelden (Hesse, Germany) up to date with the help of most modern production technology.

The LASCO sand-lime block press type KSP 850 at the Hessisches Bausteinwerk Dr. Blasberg GmbH GmbH & Co. KG has been serving reliably from the start of operation in 1994. However, the use of the new LASCO servo direct drive (see our know-how article pages 4 and 5) offers considerable potential for an increase in efficiency and performance. Therefore, the decision was made to carry out a comprehensive update of the control and drive technology.

The Dreher group with a staff of 130 and administrative headquarters in Bensheim

(Germany) excels by many years of competence and experience in the building sector (sand lime blocks, ready-mixed concrete, sand & grit and industrial sand). A range of sites in the Rhine-Main area as well as in Rhinehessen guarantee distinct customer proximity.

To upgrade the KSP 850 used in multi-shift operation as a guarantor for future requirements, the SIEMENS S5 control will be replaced by its succession type S7-317-F in combination with the high-end motion system SIMOTION and the corresponding decentralized periphery. The adaptation to the efficiency-raising LASCO servo direct drive requires the exchange of the existing variable displacement pumps and their drives for fixed displacement pumps with servo motor and frequency converter. The travel axes will also be equipped with servo motors of the latest generation. The piping of the head cover as well as actors and sensors can be maintained to a great extent.



The Hessisches Bausteinwerk GmbH & Co. KG has been using a KSP 850 for the very successful production of sand-lime blocks since 1994.

"White Stone 2017" – a successful congress in Russia

The trade conference "White Stone" organized by the association of producers of silicate products in Russia ASPI was again a big success. Experts from 18 regions of Russia as well as from Kazakhstan and Germany (among them also representatives of LASCO) participated in the two-day congress in Jaroslavl (Russia) in July 2017. The first series of seminars focused on expert talks on the production of silicate-containing building materials and their use in masonry construction. The topics of discussion ranged from the experience with new sorts of pigments (colour) to process automation, analyses of market development and scope for design in architecture. Over and above, the participants had the chance to get a practical demonstration of masonry construction with the help of a mini crane.

The second part of the conference was an excursion to the silicate brick plant in Jaroslavl. The enterprise produces blocks by analogy with the Quadro system. The conference members were able to have a close look at the use of the new calcium silicate production technology, and representatives of the technology manufacturers and suppliers answered their questions regarding the production process and the technology used.

Chinese enterprise orders two KSE 1250

Xinfa Group relies on LASCO technology

LASCO received orders for sand-lime block presses with single-acting compaction type KSE 1250 from China.

The main technological components, such as electrical equipment and hydraulics, come from the LASCO headquarters in Coburg. Final assembly and testing before shipment will then take place at the LASCO works in Hebei (China).

The order was placed by the Xinfa Group Co. Ltd. located in Chiping Country Co. Ltd., Liaocheng City, in the high-growth Shandong province. Since its foundation in 1972, Xinfa has developed into a group with more than 50 companies and holding companies and more than 15,000 employees. Its products and fields of activity are power generation, heating power, aluminium oxide, electrolytic production of aluminium, carbon, fluoride salt, caustic soda, calcium carbide, lime, vacuum salt, aluminium parts and fibreboard.

To a high degree, fly-ash is obtained as a by-product, which is used as raw material for the production of sand-lime/fly-ash blocks.

The group has its own power plants that – according to their own statements – generated more than 59 billion kWh electric power in 2016, 80% of which were used for own requirements.

LASCO servo direct drive also for retrofitting now Retrofitting pays off – especially

A few years ago, LASCO launched its refined hydraulic servo direct drive also for sand-lime block presses. Since then all LASCO presses have been equipped with this convincingly economic drive. Over and above, it is an excellent choice especially for the modernization of older presses, as described on page 3. Here are some technical explanations:

The modernization of older sand-lime block presses particularly pays off, if not only components, but the whole production line is adapted to the level of technical progress. Certainly, control and tool technology are very central aspects, but especially the retrofitting of drives that have started to show their age

to highly efficient servo drive technology will bring quality and cost benefits.

LASCO has many years of experience in retrofitting based on successfully solved tasks both in the field of forming technology and in the sector building material production.

Customers profit from this getting competent and well-structured technical advice, reliable concepts for success, smooth processing, on-schedule completion and sustainable operational safety. From the operators' point of view the modernization of existing production equipment is advisable via a strict cost-benefit-equation and short ROI. Many key targets can be reached by the optimized use of resources:

- higher performance
- better serviceability and ease of operation
- lower operational costs (wear and energy)
- compliance with latest safety regulations

Retrofitting to programmable controls combined with progressive tool technology and modern servo drive often brings about further advantages, which lead to a sustainable increase in the competitiveness of the production lines, such as more diversification, higher flexibility in the range of products and quality together with high process stability.

Power savings of up to 30%

Efficient production of sand-lime blocks means efficient production of high-quality building materials with optimized use of energy. In sand-lime block production quite a considerable part of electric energy is used in the pressing and stacking process. The hydraulic servo direct drive advanced by LASCO stands for a more efficient use of energy than conventional drives. For the same output up to 30% of the former power demand can be saved. Depending on the production volume, the investment into the new drive thus amortizes within short.

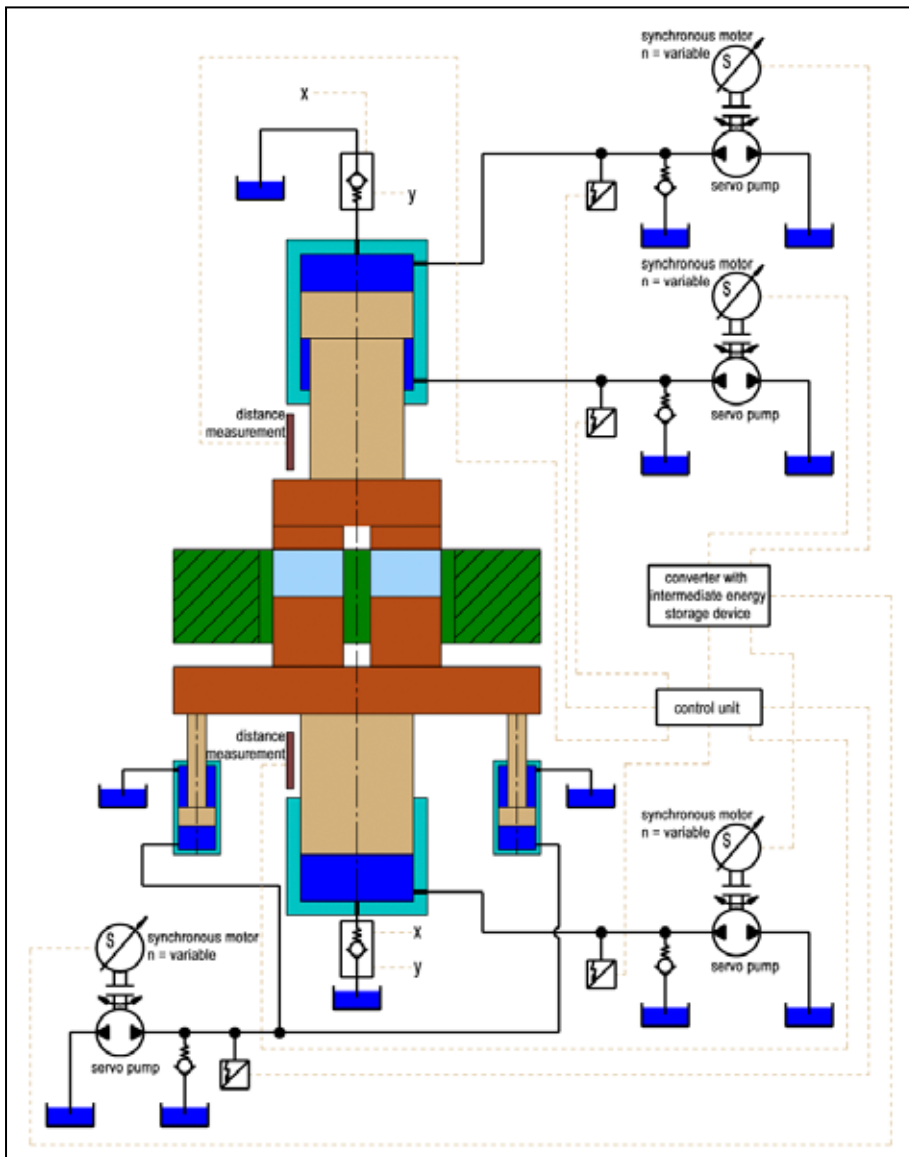

Hydraulic servo direct drive of a sand-lime block press with double-acting compression

ally with regard to the drive

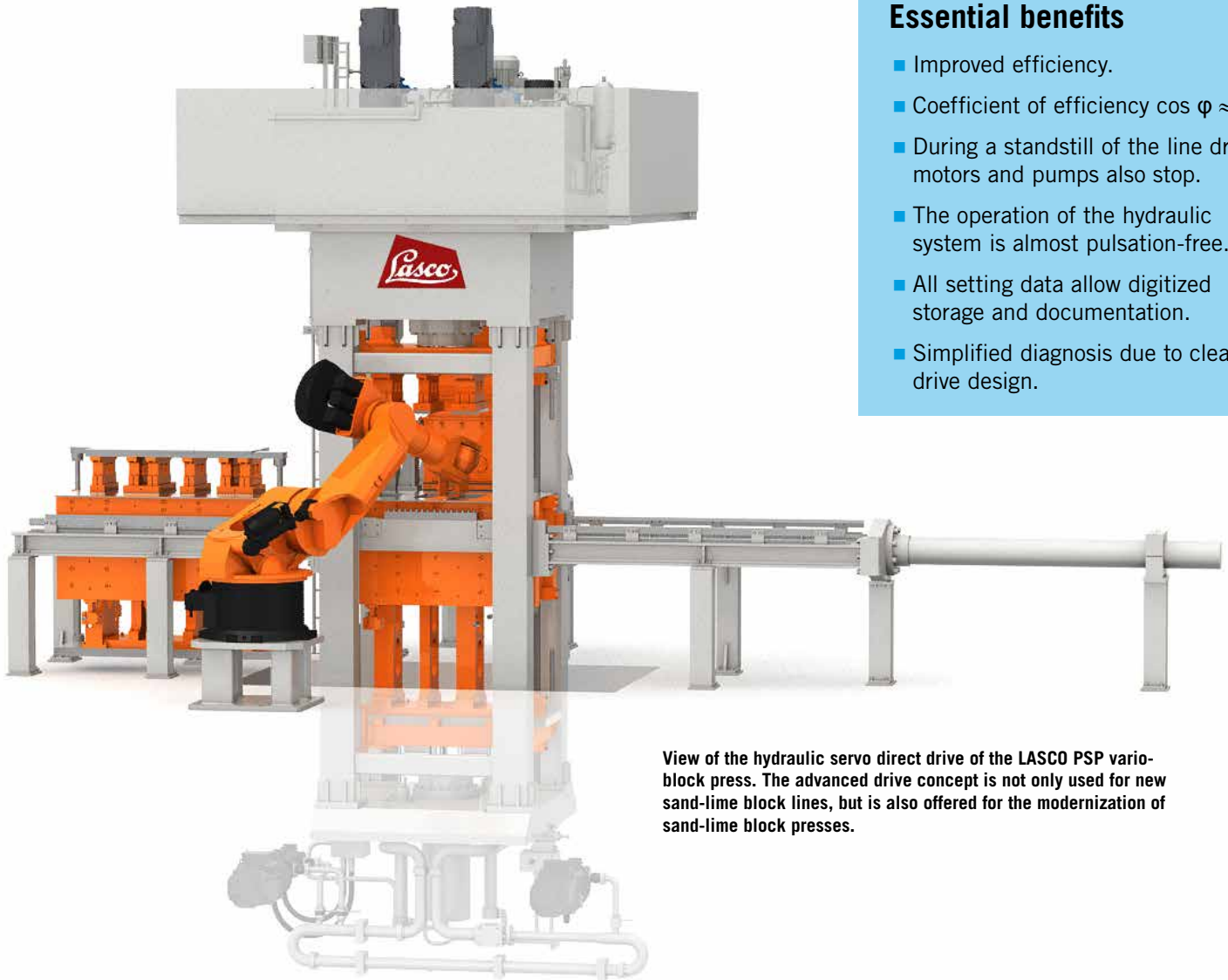

Essential benefits

- Improved efficiency.
- Coefficient of efficiency $\cos \varphi \approx 1$.
- During a standstill of the line drive motors and pumps also stop.
- The operation of the hydraulic system is almost pulsation-free.
- All setting data allow digitized storage and documentation.
- Simplified diagnosis due to clear drive design.

View of the hydraulic servo direct drive of the LASCO PSP vario-block press. The advanced drive concept is not only used for new sand-lime block lines, but is also offered for the modernization of sand-lime block presses.

Basic functional features of the hydraulic servo direct drive

At the hydraulic LASCO direct drive the hydraulic pump is directly coupled with the servo motor. The positioning of the hydraulic pistons, the adjustment of the pressing speed and the setting of force values are done without control and/or proportional valves. Only legally required safety functions still demand controllable valves and partly also valves that can be monitored.

A special feature of the direct drive is that the different effective areas of the hydraulic cylinders are supplied with hydraulic oil via separate pump drives. During the fast down movement of the upper punch the hydraulic oil flows from the drawback area into the oil reservoir via the servo pump. The speeds are

controlled by the servo motor, electric braking energy is produced in the generator mode of the servo motor and stored in the intermediate circuit of the servo system. In the subsequent pressing function, the motors use the braking energy that was fed into the intermediate circuit of the servo system before.

The hydraulic drive of the LASCO KSP and PSP presses with double-acting compaction consists of the upper punch drive as differential cylinder and the lower punch drive with the single-acting press cylinder and the two additional extension/rapid traverse cylinders. The drive of the KSE presses with single-acting compaction is designed by analogy

with the lower punch drive of the KSP/PSP presses.

The spring energy that is stored in the compressed hydraulic oil at the end of the compaction operation is used for the generative operation of pumps and servo motors in the decompression operation and for feeding produced energy into the intermediate circuit.

Such hydraulic systems have an uncomplicated design and allow very quick and simple diagnosis. The hydraulic pumps are checked for wear automatically and at regular intervals.



During the handover of the LASCO hydraulics test bench (from left): Dipl.-Ing. Ingo Ernst and Managing Director Production Robert Welsch (both LASCO), Tanja Feller (TAC), CEO Lothar Bauersachs (LASCO), Prof. Dr. Jürgen Krahl, President University East Westphalia-Lippe (formerly Managing Director TAC), Friedrich Herdan, Chairman of the Board LASCO Langenstein & Schemann, Holding, Dr. Olaf Schröder and Managing Director Caroline Rahn (both TAC).

Test system developed for University of Applied Sciences

LASCO supports research

The largest institute of the University of Applied Sciences Coburg, the “TAC – Technology Transfer Center Coburg“, is pleased about the special LASCO test bench, which was particularly developed for the purpose of research.

The project “Development of a sensor technology for finding out the state of aging of hydraulic oils during the production process“ determines the aging of various hydraulic oils via a simulated real industrial process. It is still common practice today to change hydraulic oils in manufacturing equipment at fixed time intervals as a precautionary

measure. It is the aim of the three-year research project to avoid damage to hydraulic components caused by prematurely lowered oil quality by the use and evaluation of suitable sensor technology. Another aim is to fix dynamically the oil change interval depending on the result of the oil quality analysis and to extend it considerably, if possible.

LASCO developed and realized a hydraulic test bench for this research project, which allows more quickly to parameterize and simulate various operating conditions occurring in the real production process. In addition, a sensor transmits the results to the respective machine manufacturer and/or user online thus realizing a control as required by „Industrie 4.0“ (i. e. the fourth industrial revolution).



Role models: Already for the 13th time, bayme vbm awarded the Dr. Kapp-Vorbildpreis (prize for voluntary work) to apprentices of its member companies. Together with 70 other young prize winners Sina Heß (student of mechanical engineering in dual system studies – left), Luis Flurschütz (apprentice as cutting machine operator – middle) and André Höllein (apprentice as mechatronic technician – right) were honoured for their voluntary work for the common good. In their free time, Sina Heß works as a lifeguard and voluntary ski instructor and supports a senior citizen in organizing her day-to-day life; André Höllein is member of the volunteer fire department, the Bavarian Red Cross and the rural youth at Meeder and takes care of the green areas around the pond in his home village; Luis Flurschütz works as auxiliary ski instructor, supports the organization flea market of the sports club Oberlauter and plays the tuba in a youth orchestra.



Securing the supply of skilled labour through professional training

LASCO has always regarded it as an essential task to meet its medium- and long-term demand of highly qualified skilled labour above all by first-class professional training of young people. This is why the training ratio of the company has been higher than the average in the machine tool sector for decades. Currently it is around 17 percent. On 1 September 17 young women and men started their apprenticeship at LASCO. Among the job starters are again five participants in the project “Vocational Training 1+3” within the scope of the integration of refugees from war zones. In total LASCO is training 60 job starters at the moment.

Bavarian Order of Merit for Friedrich Herdan Highest appreciation

The Chairman of the Board of the LASCO-“Holding - Langenstein & Schemann” and President of the Chamber of Commerce and Industry (CCI) Coburg has been awarded the Bavarian Order of Merit as a „token of honorific and grateful appreciation of his outstanding services rendered to the Free State of Bavaria and the Bavarian people“.

In the Antiquarium of the Munich Residence, Bavarian Prime Minister Horst Seehofer honoured Herdan as an influential entrepreneurial personality in the Coburg area, who has made the long-established company LASCO Umformtechnik GmbH with its staff of approx. 400 at the Coburg site and a total of 500 in the corporate group a global player as manufacturer of machine tools, production lines and automation technology for metal forming and the production of building materials. In addition, he has been involved in committees and functions at the Chamber of Commerce and Industry Coburg on an honorary basis. With his outstanding commitment, untiring energy and strategic farsightedness Herdan stood up vigorously for the improvement of the general economic set-up in the region in his capacity as President of the CCI Coburg, emphasized Seehofer, and in doing so, he focused special attention on the location factors transport infrastructure, recruitment of skilled labour and professional education.

Herdan campaigns for an airfield, which is fit for the future and appropriate for instrument flight, and demands the systemic connection of Coburg to the high-speed ICE rail network of German Rail (Deutsche Bahn AG).

CCI President Herdan also attaches special importance to the vocational integration of refugees with high prospects of permanent residence by developing the pilot scheme “Vocational education 1 + 3”, which is unique in Germany. This project implies the prolongation of the dual vocational education of refugees by one year and simultaneous language acquisition.

Moreover, Herdan has been town councillor in Coburg since 2008. He has also been member of the advisory board of the Technology Transfer Center Automotive (TAC) at the University of Applied Sciences Coburg since 2008 as well as member of the university council and the foundation council of the Science Foundation Upper Franconia since 2015.

Bavarian Prime Minister Seehofer emphasized that Herdan had won high recognition in his capacity as entrepreneur by his commitment to the technological and economic region. According to Seehofer, Herdan had made an outstanding contribution to the Free State of Bavaria and its citizens. In gratitude for and appreciation of his professional and diversified voluntary commitment he has been awarded the Bavarian Order of Merit.



Friedrich Herdan received the Bavarian Order of Merit from Bavarian Prime Minister Horst Seehofer (right) in the Antiquarium of the Munich Residence.

10 yaers with LASCO

| | |
|------------------|------------|
| Albert Landgraf | 01.02.2017 |
| Markus Otto | 01.03.2017 |
| Andreas Bauer | 19.06.2017 |
| Thorsten Höhmann | 01.08.2017 |
| Kai Bauersachs | 01.09.2017 |
| Faruk Ciritoglu | 01.09.2017 |
| Annemarie Galle | 01.09.2017 |
| Dominic Heidl | 01.09.2017 |
| Daniel Klimm | 01.09.2017 |
| René Müller | 01.09.2017 |
| Steffen Müller | 01.09.2017 |
| Kevin Reißweber | 01.09.2017 |
| Frank Riedel | 01.09.2017 |
| Timo Schramm | 01.09.2017 |
| Michael Fehn | 01.09.2017 |

25 years with LASCO

| | |
|---------------|------------|
| Angela Rath | 07.01.2017 |
| Robert Welsch | 01.05.2017 |
| Stefan Fink | 01.09.2017 |

40 years with LASCO

| | |
|------------------|------------|
| Matthias Löffler | 01.09.2017 |
|------------------|------------|

Sadly mourned

| | |
|----------------------|--------------|
| Joachim Niller | † 04.01.2017 |
| Siegfried Hausdörfer | † 21.07.2017 |
| Kurt Fey | † 02.10.2017 |



LASCO congratulates successful vocational training graduates

Eleven young people proved their qualification as skilled labour very successfully in the recent final examinations at the Chamber of Commerce and Industry Coburg after several years of professional training at LASCO. They received their certificates in a public ceremony at the Kongresshaus Coburg. Some of the first well-wishers were the training supervisors from LASCO. Back row (from left) Georg Pfeuffer (training supervisor), Marvin Tischer, Philipp Walter, Bastian Marx, Felix Höfer, Franziska Faber, Robin Beez; front row (from left): Björn Bühling (training supervisor), Andreas Illmer, David Lipinski, Patrick Seubold, Fabian Büchner und Alexander Zeuß

up grade ks

17th year, issue no. 17 – December 2017

Publisher: LASCO Umformtechnik GmbH
Hahnweg 139 - 96450 Coburg

Senior Editor: Jochen Günnel

Photos: LASCO Umformtechnik, Burckhard Hanke, Bayerische Staatskanzlei/Rolf Poss, Georg Weber



Hartmut Schrot
Deputy Head of Production and Engineering,
Plant Braunschweig Lüneburg
esco - european salt company GmbH & Co. KG
(Grasleben/Germany)



Salt block press for esco

Salt in the press

SOLSEL® salt blocks are produced in a “special pressing process”, as it says in the product information of the european salt company GmbH & Co. KG (esco). LASCO found out what this meant in detail, when the enterprise inquired if they were able and willing to develop an innovative new press for such sensitive products.

Creative solutions

up grade: Mr. Schrot, what brought you or rather your company to LASCO in 2014?

Hartmut Schrot: The required increase in capacity for 10 kg salt blocks and the new 25 kg salt block made a new production line necessary. We were searching a reliable partner for the project with special focus on the 25 kg salt block.

up grade: The machine builder did not have any specific experience with your product. Did you expect any particular innovation potential from him?

Schrot: We did, because it is always important to think outside the box. Of course, a company’s own experience is incorporated into such a project, but fresh ideas may help to find better solutions to a lot of problems.

up grade: Your product is sensitive. Feed and feed production must meet strict hygiene requirements. What effects did that have on cooperation?

Schrot: The hygiene requirements are very high indeed. To be able to meet them, close cooperation with the design department at LASCO was very important to coordinate e.g. good accessibility, cleaning and optimum choice of material. Thanks to this close coordination, the design department was able to consider our requests and to develop creative solutions.

up grade: What do you think, what features especially distinguish the LSP 630?

Schrot: We have always had some minor problems with space in our plant. The space-saving design of the LASCO LSP 630 provides very high ease of access to the hydraulic unit as well as to the press.

up grade: How would you describe the project from today’s perspective – after almost one year of operation?

Schrot: The project has been running well. The challenge of pressing a 25 kg salt block from extremely fine salt required an especially close dialogue of the system manufacturer and the experts on site. Currently, we are working on further improvement together with LASCO.

This is how a remarkable cooperation between esco, part of the K+S Group (K+S AG in Kassel, Germany), and LASCO started in autumn 2014, in which the machine builder was not only able to gain some knowledge about the mineral nutrient salt, but far more. All this finally led to a production line, which had not been designed and built before.

Salt blocks are feed supplement for animals, which are mainly used in agricultural meat production, horse keeping and horse breeding as well as in the preservation of wildlife. SOLSEL® salt blocks are made from pure rock salt or evaporated salt. The stability of the blocks guarantees high weather resistance as well as consistent absorption by the animal and is a competitive feature developed in long series of experiments and tested in permanent endurance tests. The machine builder had to meet the exceptional challenges of producing this stability with the porous material process-reliably and to ensure the permanent cleanliness of the production process.

After a number of basic discussions, LASCO started with the design of the new machine concept, a 4-column

press with “mould withdrawal method”, i.e. the lower die is fixed. The LSP is equipped with an automatic, volumetric mould filling device. The feed box is directly connected with the movable mould. During the pressing operation, the upper die and the mould move down in a process-controlled way. The new series was called LSP (LeckSteinPresse/salt block press).

The LASCO LSP was put into operation in the plant of Braunschweig-Lüneburg at the end of 2016, designed according to mining standards and provided with a press force of 630 kN for producing salt blocks of 10 kg as well as 25 kg. The outstanding features of the LSP are its compactness and, above all, its low construction height. All parts getting in contact with the material salt are made from high-grade steel in order to meet the hygiene requirements. Furthermore, the press is equipped with hydraulic mould and die clamping to assure exact and quick mould change. The mould is either fitted with two chambers for the production of two 10 kg blocks or one chamber for one 25 kg block. Depending on the type, the blocks are either removed by withdrawing the die or by special vacuum grippers.

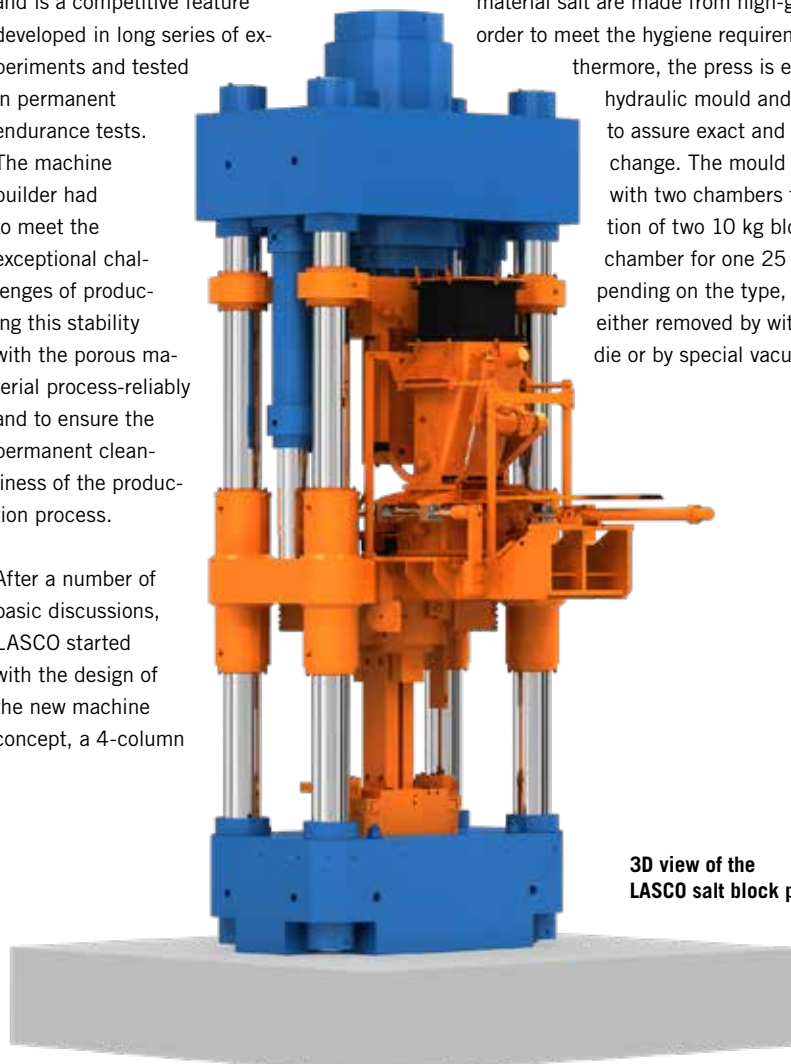

3D view of the LASCO salt block press LSP 630