



up grade

Journal (KS) for customers, partners and employees – 19th year, issue no. 19, March 2019

News

LASCO points the way to the future at bauma

The trade public can always look forward to something new when the bauma network invites visitors to one of its trade fairs in Germany, China, Russia, India, South Africa or Brazil. After participating in bauma Shanghai, LASCO will again be presenting innovations in Munich this year.

Know-how

Tech upgrade for set-up process

LASCO's award-winning vario-block press system is known for its outstanding flexibility due to the variety of possible block formats and quick format changes. This innovation has now been transferred to conventional sand-lime block presses of the KSP series.

In practice

Hydraulic press with two faces

Normally, either standard formats or system blocks resp. plan elements are produced on sand-lime block presses. The new KSP 801 for AB Silikatas in Vilnius must be able to do both, since Silikatas produces for two markets with different needs.

LASCO UMFORMTECHNIK
WERKZEUGMASCHINENFABRIK

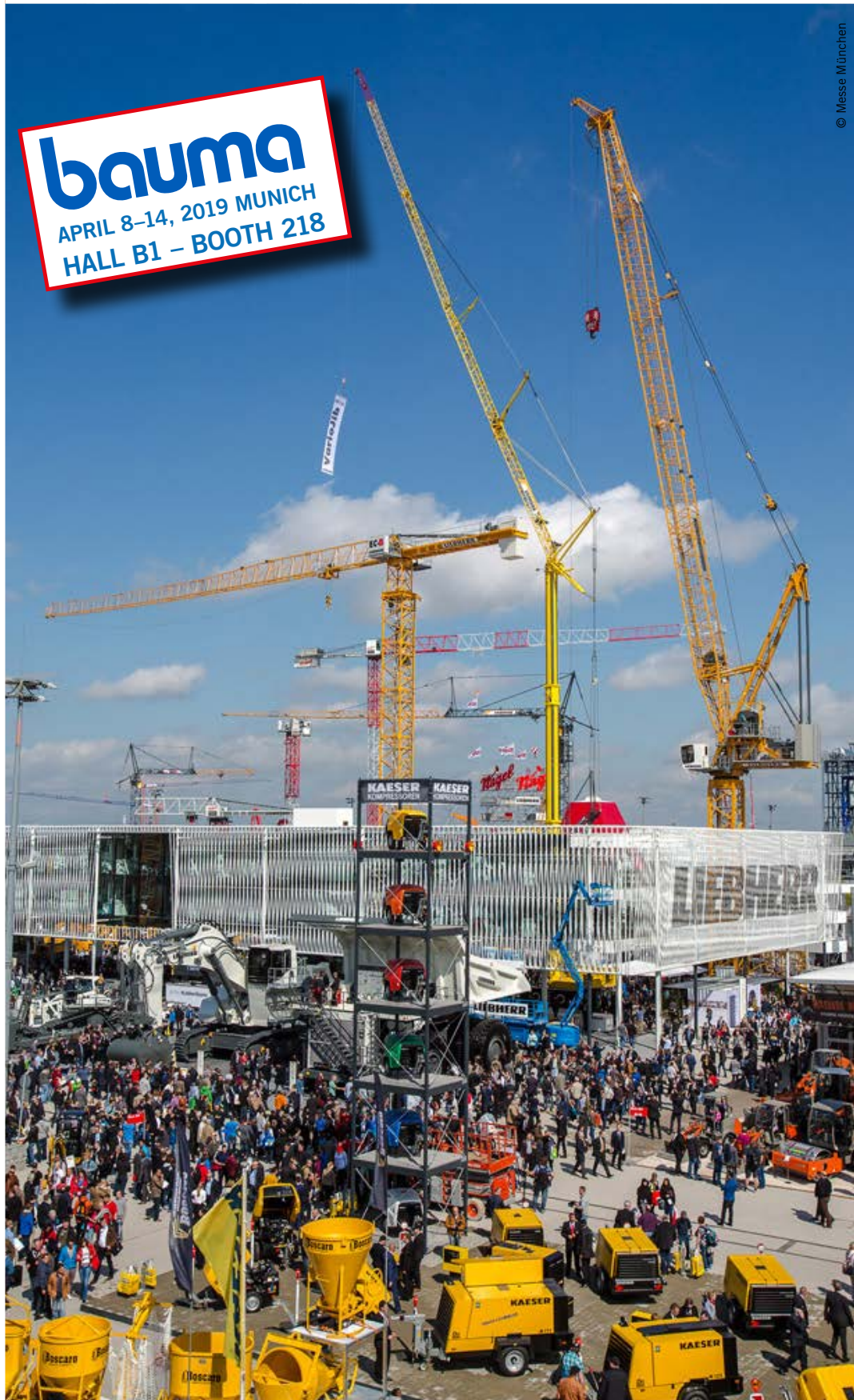



Lothar Bauersachs
CEO

Ingenuity is required

At the end of a challenging and eventful year, we are once again experiencing painfully with our partners around the world that supply and demand are not the only factors determining the market. Arbitrary political influences become strongly regulative. While we have just been pleased to register in the trade with Canada how the trade agreement „CETA“ is having a stimulating effect, we and our affected partners in other countries feel the increasingly burdensome effects of protective and penal duties, increased export and import hurdles or even sanctions. They slow down the exchange of goods and services in addition to national requirements and regulations for products that are sometimes difficult to meet, as the example of diesel engines shows.

As a company that has been operating internationally for many decades and maintains business relationships in over 100 countries around the world, we are aware that import and export barriers cause more and more difficulties to many of our customers. More than ever, ingenuity is required if proven international division of labor is to be maintained under increased and increasing demands.

LASCO is not in a position to relieve its partners of the effects of financial and logistical barriers to trade for which politicians are responsible. However, we can look for technical solutions: The technology we supply must be able to generate so much added value that the negative effects of trade restrictions are more than compensated for.

In this sense, the situation imposed on us all is an acid test of our ability, our innovative strength and the passion with which we face up to our task. I am pleased that we at LASCO have the experts who dispose of the skills and the determination to do so. That is why I look confidently ahead to the future for our customers and our company.

Yours
Lothar Bauersachs



The LASCO stand at bauma will be the focus of interest for sand-lime block producers who are looking for solutions to further increase the economic efficiency of their production.

LASCO exhibits at bauma in Munich Focus on mold technology and automation

LASCO's focus at bauma 2019 in Munich will be on its new vario-block press mold together with the largest 6-axis industrial robot with vacuum gripper commercially available at present.

LASCO, as a technology supplier to the international sand-lime block industry, will use the world's leading trade fair for construction, building materials and mining machinery in Munich from 8 to 14 April to draw attention to an increase in economic efficiency through innovative LASCO developments. The focus will be on our vario-block press technology, quick mold change and the latest variants of sand-lime block presses.

the industry does not only reach local trade visitors, but the construction industry around the globe. Messe München announces a new exhibitor record: over 3,500 exhibitors from 55 countries will present themselves - almost 100 more than in 2016.

The trade fair will be promoted by the VDMA Construction Equipment and Plant Engineering, VDMA Mining and the Committee for European Construction Equipment (CECE).

bauma as the largest international meeting place and most important multiplier for



LASCO cordially invites market partners and interested parties to visit its exhibition on 116 square meters in hall B1, booth B1.218.

Jens-Uwe Ludik new LASCO contact for producers of sand-lime products

Jens-Uwe Ludik took over the customer service of LASCO customers producing wall-building materials on 1 December 2018.

The mechanical engineer is the successor of Wolfgang Foerster, who retired on 1 September 2018.

Ludik (photo) has many years of experience in the support of industrial users of technical products, machines and lines, which he contributes to his new task at LASCO.

Mr. Ludik will introduce himself to LASCO customers in the coming months in order to get to know their experience in practical application and to take up suggestions for further developments.



Life Market's sand-lime block plant currently produces around three million blocks per month with three sand-lime block lines from LASCO.

„Life Market” has adopted legendary heritage

Back to the top

In Soviet times, the sand-lime block plant in Kirovo-Chepetsk was the largest of its kind in Russia, with an annual output of 300 million blocks. The enterprise OOO „Life Market” is now building on its great past.

Life Market is the successor of Silworld, which continued the sand-lime block production of the Strishewskij sand-lime block factory. After some reorganization in the 1990s and difficult economic times in the following years, the company made a new start. OOO „Life Market” was founded last summer to revive

the factory and the production of wall building blocks.

The company history of „Life Market” might be short, but it is surely successful: With the help of OOO „LASCO Umformtechnik Service” in Russia, the production facilities got a complete technical update, the product range was expanded and the machinery supplemented with three highly productive LASCO KSE 401 lines. Today „Life Market” is the leading manufacturer of sand-lime blocks in the region. The products - solid, perforated and colored facing blocks of Russian standard format - are sold not only in the Kirov region, but also in other regions of the Russian Federation. In the future, plan elements and system blocks will also be produced.



With a current staff of about 90, Life Market is one of the most important employers in the rural region of Strishi.

bauma CHINA – the future is smart, digital and sustainable

Another chapter has been added to the success story of bauma CHINA: The 9th International Trade Fair for Construction Machinery, Building Material Machines, Mining Machines and Construction Vehicles took place in November at the Shanghai New International Expo Center (SNIEC). The trend: smart, digital, sustainable. A total of 3,350 exhibitors from 38 countries and regions gathered on 330,000 square meters of exhibition space. The trade fair recorded 212,500 visitors, i.e. an increase of 25 percent - 94 percent of them came from Asia. LASCO exhibited on its own stand in the „German Pavilion”. The hydraulic sand-lime block press KSE 1250 B as well as the new technologies for vario-block presses attracted the attention of numerous trade visitors and market partners from China, Korea, Russia, India and Malaysia.

Fairs + Dates

bauma
Munich, Germany
08.-14.04.2019

bauma CTT
Moscow, Russia
04.-07.06.2019

Technology transfer for quick change of sand-lime block

Speed boost during set-up process

LASCO's patented vario-block press system has facilitated the production of supplementary blocks in variable geometries in a way that was hardly considered possible in the industry 15 years ago. However, the advantage of the unique flexibility of the system has been limited to the vario-block press so far.

Our PSP vario-block press system has been refined continuously over the last 12 years. In 2007, we received the Innovation Award of the German Construction Industry in the field of machine tools for the construction of the first PSP vario-block press line as a fully automatic system for supplementary blocks in the sand-lime block element system. On the occasion of bauma 2010 we presented the further development doubling the possible block formats from four to eight.

The integration of a green block saw for the reworking of individual blocks obviated the need for separate equipment for this processing step and thus optimized investment and follow-up costs considerably. Furthermore, two molds with four different wall thicknesses came into operation. This has made it possible to produce vario-block elements in heights of 498 mm and 623 mm without changing molds. With the integrated green block saw, gable and beveled blocks can be

customized individually. The unloading robot removes the green vario-blocks and stacks them on the curing wagon according to programming.

In 2012, the vario-block press technology - consisting of a vario-block press for pressing the elements in variable lengths and a green block saw for sawing height and gable cuts - was supplemented by a green block slitting saw for producing masonry slits. The prerequisite for this was the preparation and further processing of the unitization data by a special unitization software.

In 2018, we started to transfer the quick mold set-up process of the PSP to conventional sand-lime block lines of the KSP series. Taking into account customer requirements for an optimization of the set-up times, we have developed a system which reduces the very time-consuming alignment of the upper and lower punches with the mold box to a minimum.

This drawing illustrates the working principle of the shifting tool in the vario-block press.

Procedure: While production is running with the first mold box, the already prepared second box is waiting to be used. By selecting the desired program step, the molds are shifted, the new mold is fixed and automatically aligned. Production is only stopped for a few minutes.

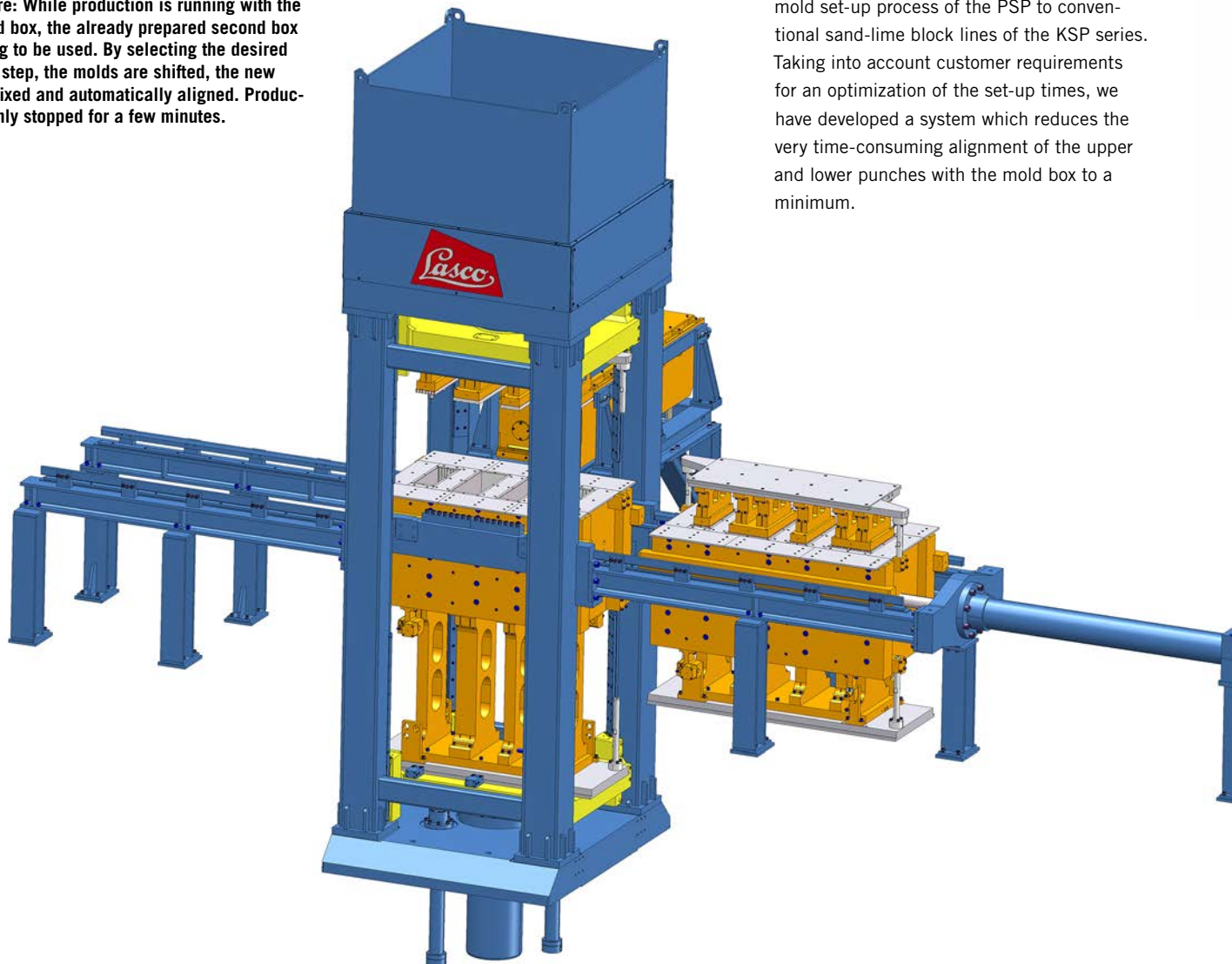

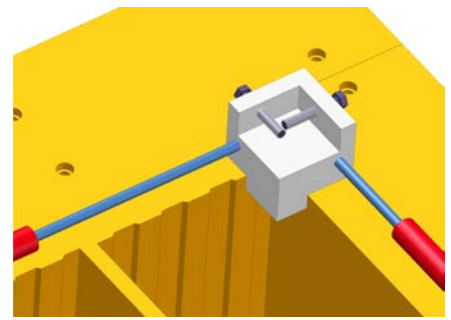
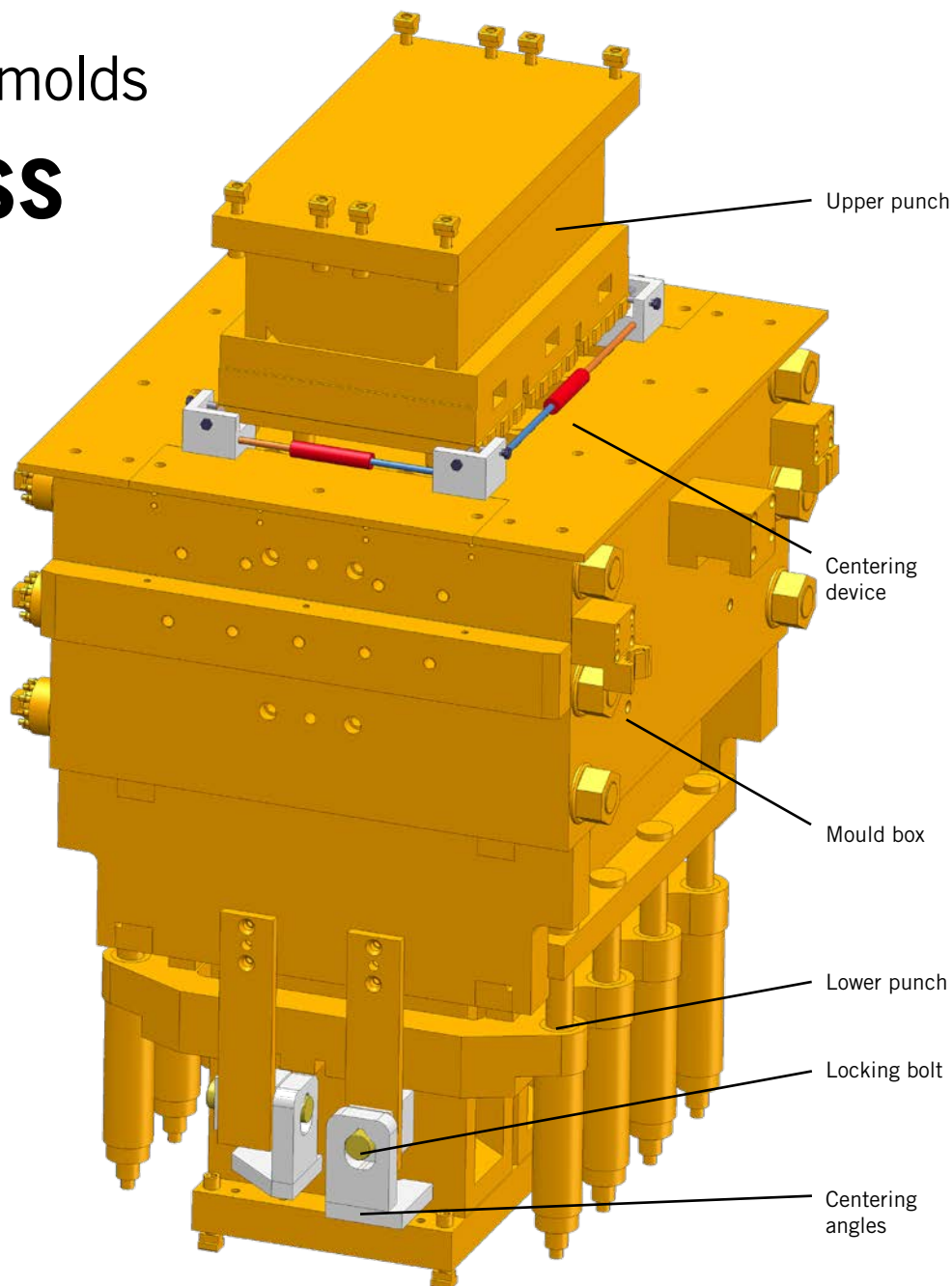

Detailed view threaded spindle

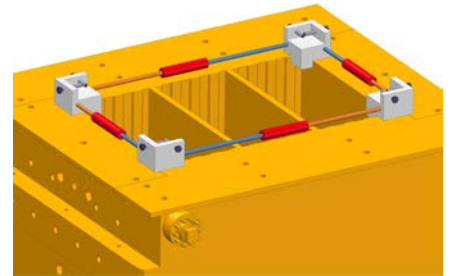

Centering device with mould box and press table

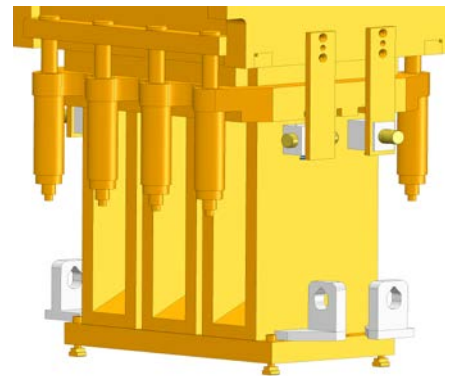

Centering device with mould box and press table
Lower punch with mandrel frame

The features of the new system using the example of a Quadro mold box (schematic view)

Preliminary set-up of molds for our KSP series during ongoing production

Basically, two new features lead to shorter set-up times and explain this improvement.

- Four centering angles on the lower punch in combination with the pneumatically actuated locking bolts on the mold box automatically align the lower punch with the mold box. The optimally arranged recesses for the locking bolts prevent a displacement in x- and y-direction.

- The separate centering device on the top surface of the mold box allows quick and easy centering of the upper punch with respect to the mold box. The upper mold is aligned manually with threaded spindles and adjusting screws already during the preliminary set-up process, i.e. while production is still running. After the mold package has been inserted into the press and the upper mold is fixed to the upper punch, the centering frame can be removed easily.

Most of the above process steps can be carried out outside the press during operation. For the first time, this allows a fast mold change even with conventional sand-lime block lines, which, of course, has a positive effect on production capacity.





Securing of the future and growth

Record level of vocational training at LASCO

20 school leavers began their vocational training at LASCO in September. Contrary to the general trend, LASCO has created additional training places, all of which have been filled with qualified applicants.

With a training ratio of 17 percent, well above the average in the industry, the company believes it is well equipped to counter the shortage of skilled workers. „It makes us proud to welcome so many young professionals. With us, you will find an excellent opportunity for your professional development. We need competent people in order to master

the challenges of the future,” said Lothar Bauersachs, CEO.

With the new apprentices, a total of 66 young people will be trained at LASCO to become qualified specialists in technical and commercial professions, 14 of whom studying mechanical engineering, electrical engineering, automation technology & robotics and business administration in the integrated dual studies program. In 2018, too, four young refugees (seven in total) will again receive dual vocational training and become part of the LASCO corporate community within the framework of the combined model „1 + 3”, which has been in practice since 2016.

The trainees together with CEO Lothar Bauersachs (l.), as well as persons in charge of training and human resources.



Specialists with top perspectives

Thanks to the thorough vocational training at LASCO, the young people who have mastered their final examinations this year have the best prospects of a good career future. LASCO is pleased with the performance of the junior staff and congratulates them on their success.

Picture left: the graduates of the industrial-technical professions with their supervisor (back from left) Sebastian Bachmann, Markus Löhnert, Felix Holzheimer and Manuel Scheurer as well as (front from left) Andreas Kaul, Florian Hartel, Björn Bühling (supervisor) and Steven Pochlebaev.

Picture right: (from right) LASCO CEO Lothar Bauersachs with the graduates of commercial professions Lukas Zapf (IT specialist for system integration), Jan Pietschmann (industrial clerk) and Maximilian Bauer (industrial clerk/integrated dual studies program).

10 years with LASCO

Volker Thauer	16.06.2019
Maximilian Escher	01.09.2019
Mario Giuffrè	01.09.2019
Felix Reisenweber	01.09.2019
Tobias Ross	01.09.2019
Matthias Schneider	01.09.2019
Bianca Höfler	01.11.2019

25 years with LASCO

Manfred Wagner	01.08.2019
Andreas Hübner	01.09.2019
Christian Lorch	01.09.2019
Bernd Schubert	03.09.2019

40 years with LASC O

Elke Hornung	01.09.2019
---------------------	------------

Sadly mourned

Hermann Rauschert	+ 23.05.2018
Friedrich Hüttner	+ 24.06.2018
Klaus Taubmann	+ 09.06.2018

up grade ks

19th year, issue no. 19 – March 2019
Publisher: LASC O Umformtechnik GmbH
 Hahnweg 139 - 96450 Coburg
Senior Editor: Jochen Günnel
Photos: LASC O, 000 Life Market, Silikatas
 Akciné Bendrové, Burckhart Hanke, IHK zu
 Coburg, Messe München

Representatives of Coburg businesses made unanimous decision at the CCI General Assembly

CCI President Herdan re-elected

Friedrich Herdan, Chairman of the Management Board of LASCO Langenstein & Schemann, Holding, has been appointed President of the Chamber of Commerce and Industry in Coburg for a further four years and is taking up his 4th term of office as CCI President.

The election decision of the General Assembly was taken without a dissenting vote. One of the first congratulators on the re-election was Bavarian Prime Minister Dr. Markus Söder. He described Friedrich Herdan as an upright representative of the interests of the Coburg region vis-à-vis the Bavarian State Government. Dr. Söder thanked Herdan for „good ideas, outstanding dedication and great time commitment” to the region in the north of Franconia.

The Coburg Chamber of Commerce and Industry represents around 8,500 commercial enterprises in the Coburg economic region,



Friedrich Herdan presents to Bavarian Prime Minister Dr. Markus Söder (left) the Prince Albert Teddy Bear, which was created by the Coburg Teddy Bear Factory Hermann on the occasion of the 200th birthday of the British Queen Victoria and her Coburg husband Prince Albert of Saxony-Coburg and Gotha.

which has its strengths in mechanical engineering, the insurance industry and the automotive supply industry. Friedrich Herdan has held the honorary office of President for more than 10 years. He was first elected in 2008. Since then he has been intensively involved in the development of the region's infrastructure and the sustainable securing

of the supply of skilled workers, in particular by intensifying training and further education as well as the integration of migrants. His initiatives include the founding of the Technical College for Machinery, Equipment and Automotive and its establishment in Coburg, as well as the recognized pilot model „1+3” for the training of refugees.

„LASCO AR” available free of charge in Play-Store and App-Store

Experience virtually machine functionality

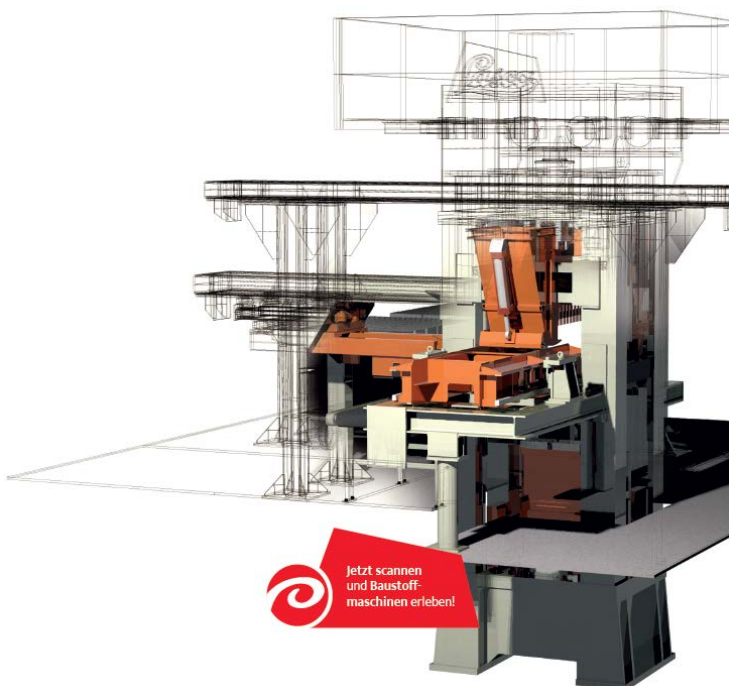

Hold your smartphone or tablet with the camera over the picture and learn more about how the system works.

With the help of „LASCO AR”, smartphones and tablets can make the functionality of machines and systems virtually visible and tangible. The app is provided by LASCO free of charge.

As part of the technical development under the aspects of „Digitization” and „Industry 4.0”, LASCO is making available for the first time an application that enables the use of „Augmented Reality” in order to make the functionality of complex machines, systems and production processes more comprehensible. First applications are available. The service will be expanded.

Download and install the app for free via the App Store (Apple/iOS) or Play Store (Google/Android). To do this, scan the QR code (right) with your device or enter „LASCO-AR” in the search function of the store. If you have already installed „LASCO-AR”, please update your app.



Open and use the app wherever the LASCO AR logo (right) is displayed, e.g. in the demo printed on the left.





Vytautas Česnauskas
General Manager
Silikatas Akcinė Bendrovė
(Vilnius/Lithuania)

Things running smoothly

up grade: Herr Česnauskas, your company has been producing wall-building materials for 60 years. What has changed in this time?

Vytautas Česnauskas: The market economy has successfully replaced the planned economy, and Silikatas has become a public limited company with private shareholders. The top priority is no longer to fulfil political directives, but to maximize the increase in value by fulfilling customer wishes in the best possible quality.

up grade: You seem to be quite successful here with your factory.

Česnauskas: We are pleased with the appreciation of our products both in the domestic market and in neighboring Russia. This motivates us to supply our customers with even better quality in even larger quantities at fair prices. Therefore, we decided to buy a new, very advanced production line and to cooperate with LASC0.

up grade: What experience have you gained from this project?

Česnauskas: The system absolutely meets our expectations – although many features do not correspond to the standard version of the press type. In the planning and design phase, we benefited in this respect from LASC0's many years of experience with custom-made or modified machine tools and automation technology. Right from the start, we had the good feeling that we were dealing with professionals who knew exactly what and how something could be done and whether the realization of an option had a lasting increase in value or not. That gave us a lot of security.

up grade: What future do sand-lime blocks have in your region?

Česnauskas: As a wall-building material, sand-lime blocks have great future potential because they really have a lot to offer in terms of durability, energy efficiency – i. e. thermal insulation – and environmental friendliness.



Silikatas Akcinė Bendrovė (Vilnius) On a double mission

The first cooperation historically seen between the Lithuanian building materials producer AB Silikatas and LASC0 was marked by a special challenge: The company needed a production line that could produce diversified sand-lime blocks for two different markets.

First, it is about „ARKO“, because this is the brand name of the sand-lime bricks and blocks that Silikatas has been producing in Vilnius since 1954. On the one hand, large-sized blocks of different wall thicknesses are produced in the Lithuanian format 340 mm x 198 mm. On the other hand, there are also the much smaller standard format blocks that are in demand in the market of neighboring Russia. The mechanical press used so far could no longer keep up in terms of quality and economy, not with the demands of the time - and certainly not with those of the future.

The need for advanced production equipment at Silikatas is driven by demand: 26.5 million ARKO blocks were produced by 2017. But the company could have sold more. Demand for wall-building materials, which was already good, rose sharply again last year due to the mild weather and a general increase in construction activity. Silikatas recorded sales growth of 30%.

Increase in capacity, quality and efficiency - three goals that Silikatas wanted to achieve, preferably with a single machine. The solution was found in a hydraulically driven KSP 801 with double-acting compaction from LASC0 with various special equipment.

The KSP 801 had to be individually equipped in order to be able to produce wall-building materials in different national formats. Due to

the different block heights, the press required not only a significantly larger mold installation area compared to the standard version, but also higher press force. Special equipment is also the automatic water dosing: The moisture of the sand-lime mass is measured exactly with a calibrated probe and the required water supply is controlled via special valves. In addition, the line is equipped with an automatic stacking device, unique in Lithuania. Press and automation were also adapted to the spatial conditions, so that the available space of the existing press hall could be used optimally.

The assembly of the line in Vilnius will be supported by the LASC0 subsidiary OOO „LASC0 Umformtechnik Service“ in Vladimir, Russia.



The LASC0 line for Silikatas in an assembly hall at the LASC0 headquarters in Coburg shortly before delivery to the site of operation in Lithuania.